

Differential Carrier

Special Tool(s)

 <p>ST1485-A</p>	<p>Installer, Differential Shim 205-220 (T85I-4067-AH)</p>
---	--

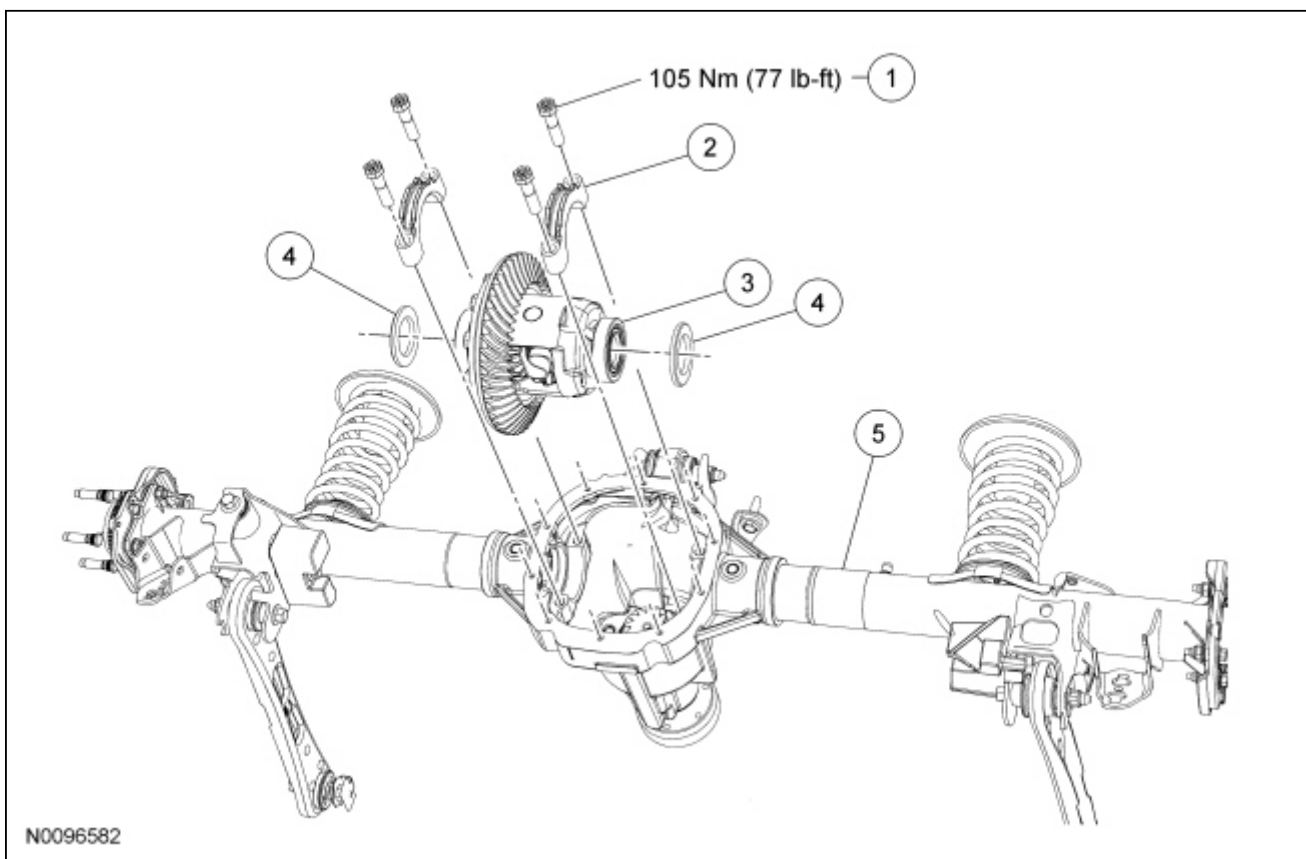

Item	Part Number	Description
1	—	Differential bearing cap bolt (4 required)
2	—	Differential bearing cap (2 required)
3	4204	Differential assembly
4	4067	Differential bearing shims (2 required)
5	4010	Axle housing

Removal

1. Remove the axle shafts. For additional information, refer to [Axle Shaft](#) in this section.
2. **NOTE:** Index-mark the position of the differential bearing caps, as arrows may not be visible. The differential

bearing caps must be installed in their original locations and positions.

Remove the 4 differential bearing cap bolts and the 2 differential bearing caps.

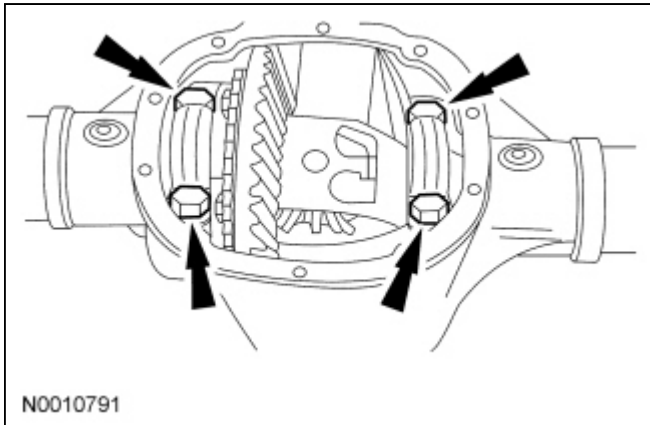

3. **NOTE:** Place a wood block between the pry bar and the axle housing to protect the machined surface from damage.

NOTE: Index-mark the position of the differential bearing shims. The differential bearing shims must be installed in their original locations and positions.

Using pry bars and wood blocks, remove the differential carrier assembly from the axle housing.

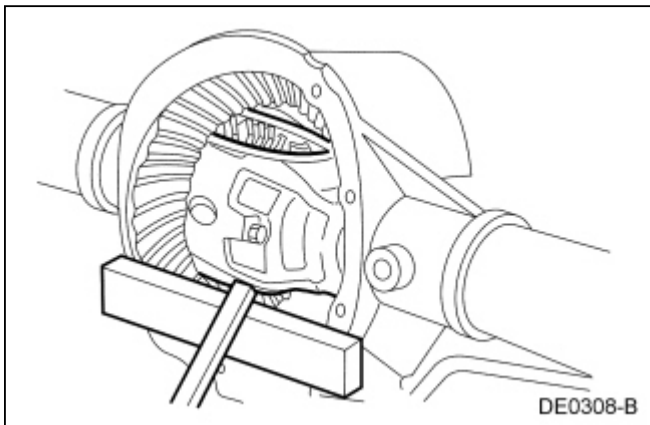

Installation

1. Position the differential assembly in the axle housing.

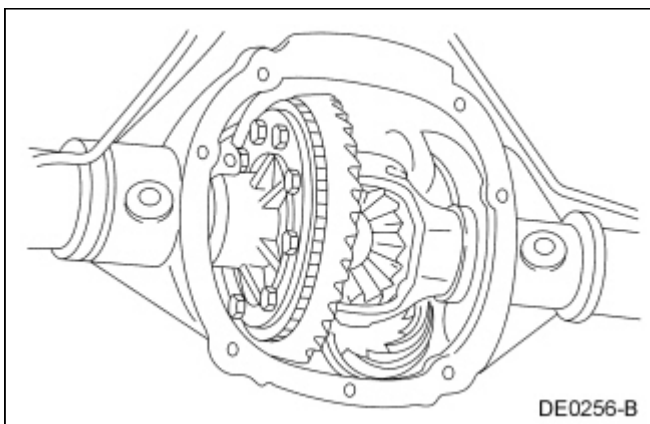

2. Install the originally removed differential bearing shim on the LH side.

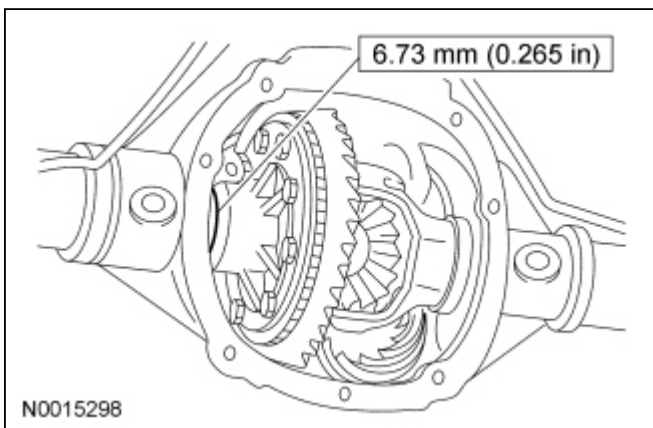

3. **NOTE:** Apply pressure toward the LH side to make sure the LH differential bearing cap is seated.

Install the LH differential bearing cap and loosely install the 2 differential bearing cap bolts.

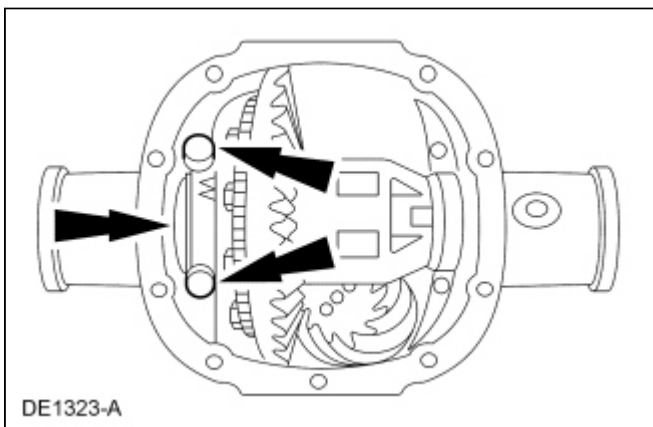

4. Install the original differential bearing shim on the RH side.

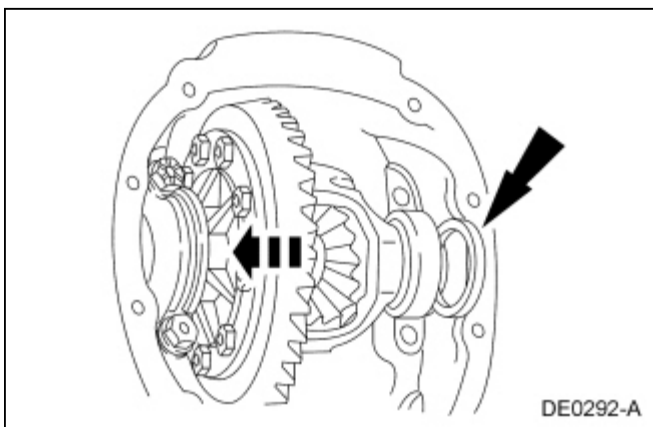

5. Using the Differential Shim Installer, fully seat the differential bearing shims.

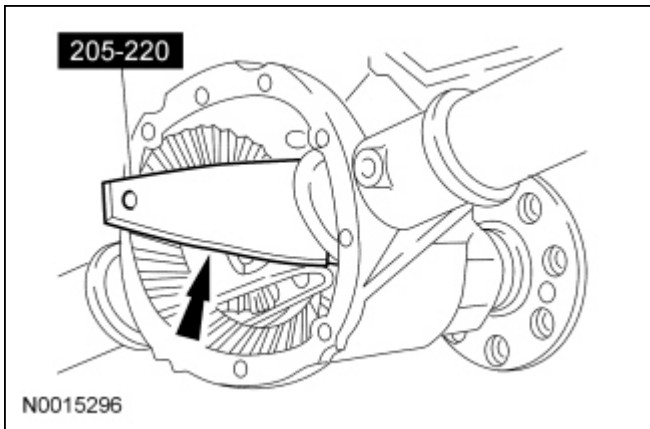

6. Install the RH side differential bearing cap and tighten the 4 differential bearing cap bolts.
 - Tighten to 105 Nm (77 lb-ft).

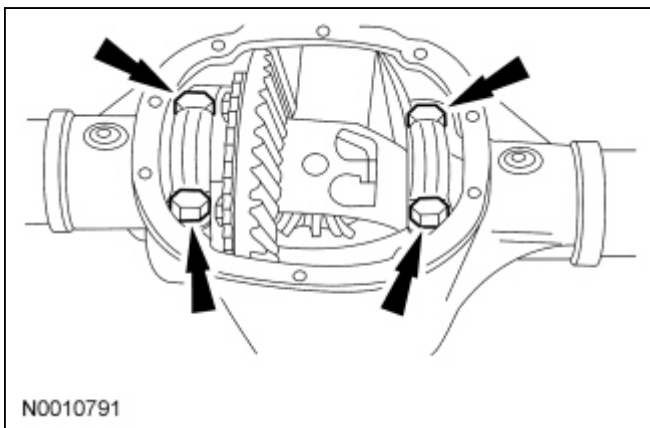

7. Rotate the differential assembly to make sure it rotates freely.

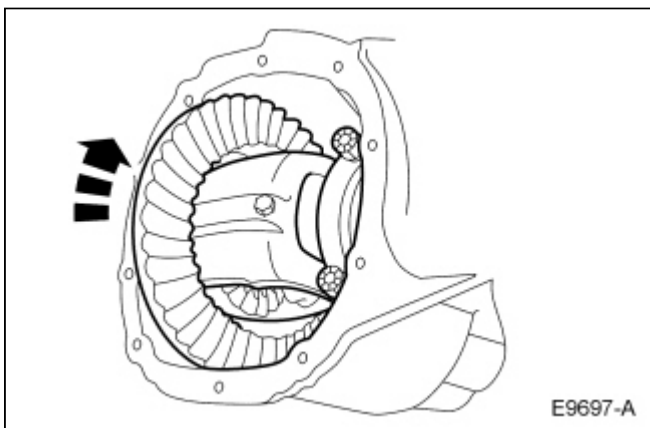

8. Adjust the ring gear backlash. For additional information, refer to [Ring Gear Backlash Adjustment](#) in this section.
 9. Install the axle shafts. For additional information, refer to [Axle Shaft](#) in this section.
-

